

# ART 141GB

## Ductile Iron Butterfly Valve Lugged & Tapped

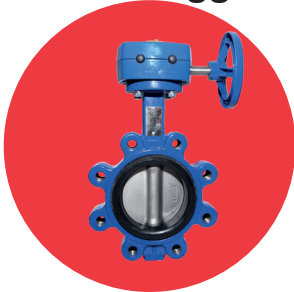

### Features

- Flanged mounting PN16 only
- BS5155 (BS EN 593)
- ISO 5211 direct mount
- Epoxy coat finish
- MSS-SP-67

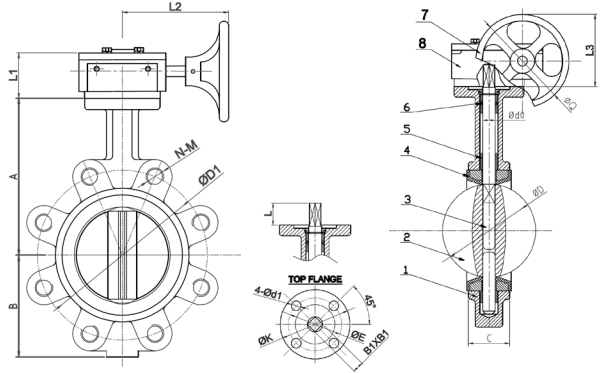

### Technical data

Max pressure: 16 Bar  
Working temp: -10°C to +110°C

DN	2"	2 1/2"	3"	4"	5"	6"	8"	10"	12"	14"
A	140	150	158	176	190	211	235	265	305	368
B	80	89	95	114	127	139	175	203	242	267
C	42	44.7	46	52	54.4	55.8	60.6	66.2	76.9	76.5
D	53	65	79	104	123.3	155.1	202.5	250.5	301.5	333.3
d0	12.6	12.6	12.6	15.8	18.9	18.9	22.1	28.5	31.6	31.6
B1	9	9	9	11	14	14	17	22	22	22
L	26	26	26	28	28	28	36	36	36	42
D1	125	145	160	180	210	240	295	355	410	470
N-M	4-M16	4-M16	8-M16	8-M16	8-M16	8-M20	12-M20	12-M24	12-M24	16-M24
L1	62	62	62	62	62	62	76	76	75	75
L2	156	156	156	156	156	156	208	208	186	186
L3	106.5	106.5	106.5	106.5	106.5	106.5	178.5	178.5	177.0	177.0
Q	147	147	147	147	147	147	278	278	278	278
Kv	90.97	191.44	360.93	892.66	995.29	1705.87	3182.92	4961.15	9252.07	10212
Kgs	6.6	7.2	8.1	9.9	11.8	13.8	24.3	34.6	51.6	58.3

### N. Part Name Materials

1	Body	Ductile Iron GGG40
2	Disc	Stainless Steel 316
3	Shaft	Stainless Steel 410
4	Seat	EPDM
5	Bushing	PTFE
6	O-Ring	EPDM
7	Handwheel	Cast Iron
8	Gear	Cast Iron

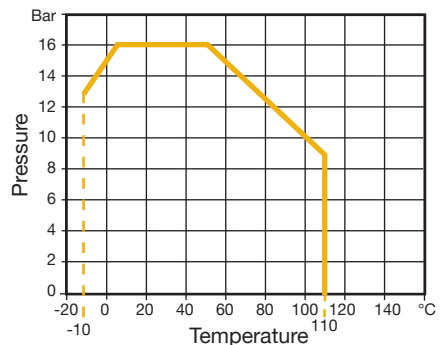

V2. Dimensions in mm

This data sheet is designed as a guide and should not be regarded as wholly accurate in every detail. We reserve the right to amend the specification of any product without notice.