

ART 23 PRS

DZR Double Regulating Valve (DRV)



Features

- Universal M & V Profile with 15mm to 35mm
- Dedicated M Profile 42mm & 54mm
- Handwheel with shut off function and clear 360° reading
- Digital scale with memory lock pre-set function via 3mm Allen key
- Tested in accordance to BS EN 12266-1
- 5 year warranty

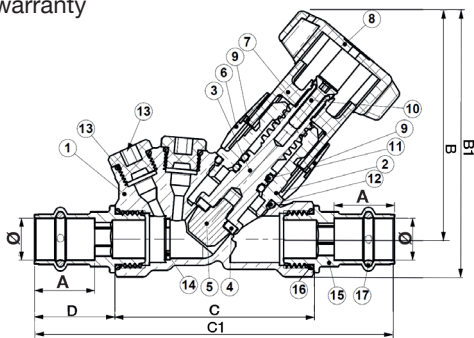

Technical data

Max pressure: DN15 24 Bar
 DN22 & DN28 20 Bar
 DN35 to DN54 17 Bar

Working temp: -10°C to 120°C

DN	15L	15	22	28	35	42	54
Ø	15.3	15.3	22.4	28.3	35.3	42.4	55.6
A	22	22	25	27	27	32	33
B	83.4	83.4	82.2	84.2	86.9	106.7	103.6
B1	97.1	97.1	99.5	104.4	111.9	136.2	138.6
C	72.5	72.5	82	95	122	138	161
C1	131.5	131.5	150	167	194	223	255
D	29.5	29.5	34	36	36	42.5	47
Kv	0.533	2.00	3.88	7.28	13.39	18.60	30.10
Kgs	0.45	0.46	0.55	0.72	1.15	1.71	2.03

N.	Part Name	Materials
1	Body	DZR Brass CW602N-M
2	Bonnet	DZR Brass CW602N-M
3	Stem for Shutter	DZR Brass CW602N-M
4	Shutter Gasket	EPDM
5	Disc	DZR Brass CW602N-M
6	Fixed Index	POM
7	Entrainer	Nylon 6
8	Knob	Nylon 6
9	1/10 Turn Index	POM
10	Memory Screw	Steel
11	Stem O-Ring	EPDM
12	Bonnet O-Ring	EPDM
13	Plug with O-Ring NBR	Nylon 6.6 / NBR 70SH
14	Fixed Orifice	DZR Brass CW602N-M
15	Joint	DZR Brass CW511L-DW
16	O-Ring	EPDM
17	O-Ring	EPDM

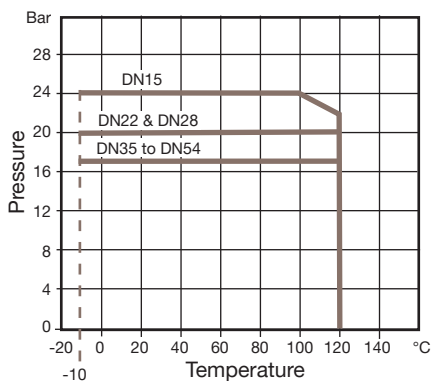

ART 23 PRS

DZR Double Regulating Valve (DRV)

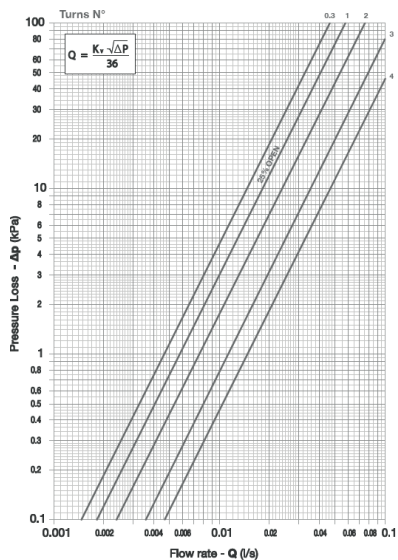

DN15L

Full turns	Kv (Flow rate in m³/h @ 1 bar pressure drop)									
	Tenths of a turn									
	0.0	0.1	0.2	0.3	0.4	0.5	0.6	0.7	0.8	0.9
0	-	-	-	0.165	0.173	0.180	0.186	0.191	0.196	0.200
1	0.204	0.209	0.213	0.218	0.223	0.229	0.236	0.243	0.251	0.260
2	0.270	0.281	0.293	0.305	0.318	0.332	0.347	0.362	0.378	0.394
3	0.410	0.426	0.442	0.457	0.472	0.486	0.499	0.510	0.520	0.528
4	0.533									

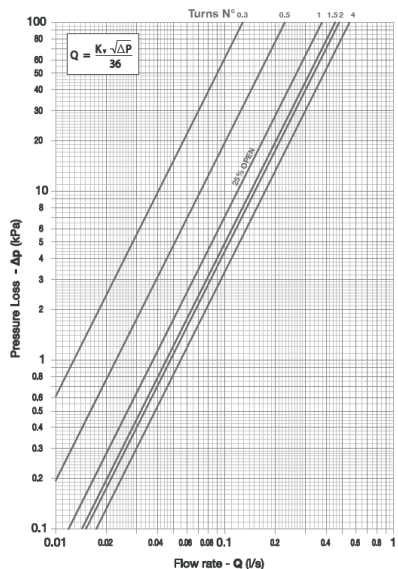

DN15

Full turns	Kv (Flow rate in m³/h @ 1 bar pressure drop)									
	Tenths of a turn									
	0.0	0.1	0.2	0.3	0.4	0.5	0.6	0.7	0.8	0.9
0	-	-	-	0.47	0.68	0.83	0.98	1.10	1.20	1.29
1	1.37	1.44	1.50	1.55	1.61	1.64	1.67	1.69	1.71	1.72
2	1.73	1.74	1.74	1.76	1.78	1.81	1.84	1.86	1.88	1.89
3	1.90	1.92	1.93	1.95	1.97	1.98	1.98	1.99	2.00	2.00
4	2.00									

ART 23 PRS

DZR Double Regulating Valve (DRV)

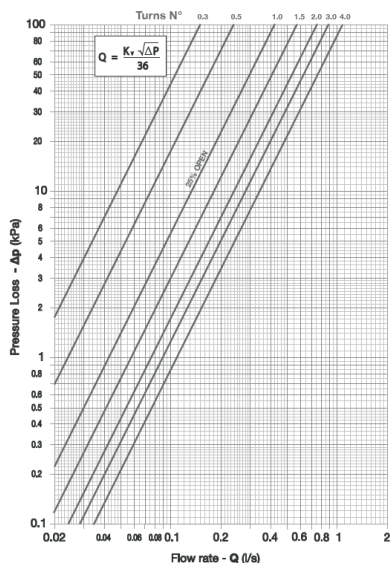

DN22

Kv (Flow rate in m ³ /h @ 1 bar pressure drop)										
Full turns	Tenths of a turn									
	0.0	0.1	0.2	0.3	0.4	0.5	0.6	0.7	0.8	0.9
0	-	-	-	0.54	0.73	0.89	1.04	1.16	1.30	1.42
1	1.54	1.64	1.74	1.84	1.93	2.03	2.10	2.17	2.26	2.31
2	2.37	2.42	2.48	2.53	2.58	2.63	2.71	2.82	2.96	3.04
3	3.17	3.31	3.44	3.54	3.64	3.70	3.76	3.80	3.82	3.83
4	3.88									

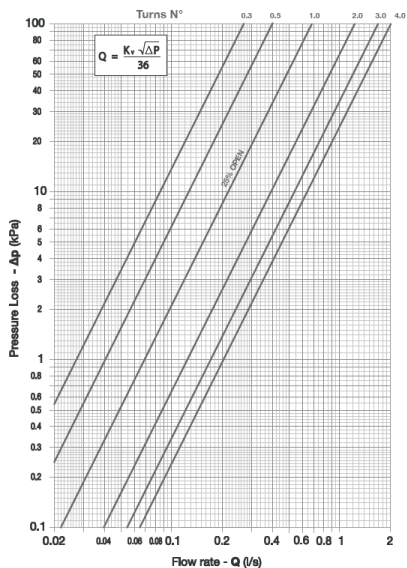

DN28

Kv (Flow rate in m ³ /h @ 1 bar pressure drop)										
Full turns	Tenths of a turn									
	0.0	0.1	0.2	0.3	0.4	0.5	0.6	0.7	0.8	0.9
0	-	-	-	0.96	1.21	1.45	1.65	1.84	2.04	2.25
1	2.46	2.66	2.87	3.09	3.32	3.54	3.74	3.91	4.10	4.24
2	4.43	4.59	4.78	4.98	5.17	5.34	5.51	5.67	5.82	5.98
3	6.09	6.24	6.38	6.51	6.65	6.79	6.89	6.99	7.08	7.19
4	7.28									

ART 23 PRS

DZR Double Regulating Valve (DRV)

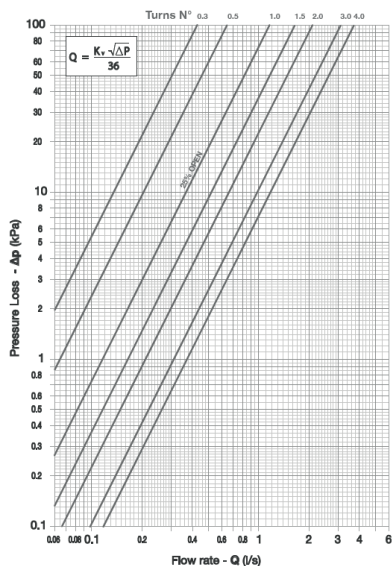

DN35

Kv (Flow rate in m ³ /h @ 1 bar pressure drop)										
Full turns	Tenths of a turn									
	0.0	0.1	0.2	0.3	0.4	0.5	0.6	0.7	0.8	0.9
0	-	-	-	1.56	1.96	2.34	2.68	3.04	3.40	3.80
1	4.15	4.51	4.85	5.18	5.55	5.89	6.21	6.52	6.91	7.21
2	7.56	7.86	8.17	8.50	8.92	9.30	9.68	10.06	10.42	10.89
3	11.27	11.62	11.98	12.37	12.70	12.93	13.06	13.19	13.27	13.33
4	13.39									

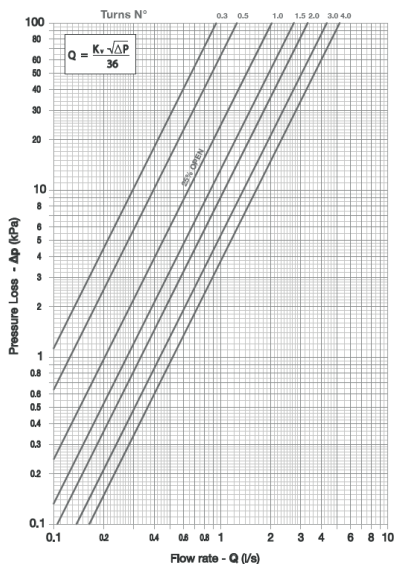

DN42

Kv (Flow rate in m ³ /h @ 1 bar pressure drop)										
Full turns	Tenths of a turn									
	0.0	0.1	0.2	0.3	0.4	0.5	0.6	0.7	0.8	0.9
0	-	-	-	3.37	4.08	4.51	5.12	5.60	6.16	6.78
1	7.32	7.90	8.43	9.00	9.53	9.88	10.30	10.73	11.16	11.63
2	11.97	12.36	12.78	13.19	13.53	13.92	14.28	14.57	15.01	15.35
3	15.69	16.01	16.43	16.71	17.02	17.24	17.52	17.85	18.10	18.27
4	18.69									

ART 23 PRS

DZR Double Regulating Valve (DRV)

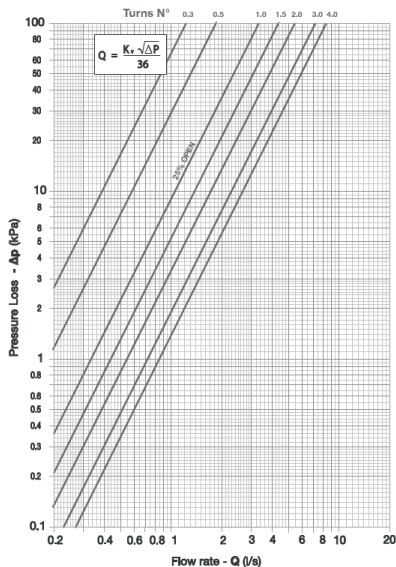

DN54

Kv (Flow rate in m ³ /h @ 1 bar pressure drop)										
Full turns	Tenths of a turn									
	0.0	0.1	0.2	0.3	0.4	0.5	0.6	0.7	0.8	0.9
0	-	-	-	4.39	5.65	6.72	8.07	8.97	10.04	11.06
1	11.77	12.62	13.51	14.28	15.05	15.73	16.25	17.14	18.06	18.81
2	19.44	20.10	21.04	21.81	22.53	23.12	23.88	24.28	24.75	25.36
3	26.06	26.48	26.91	27.24	27.66	28.10	28.44	28.80	29.17	29.76
4	30.10									